



---

Date: Mar 10, 2024

Job: AWIC 12X14 COOLER SINGLE PHASE

Customer: AWIC 12X14 COOLER SINGLE PHASE

Customer Details: -

General Contractor: -

Submitted By: -



**12X14 COOLER - Box Load Calculation****General Requirements**

Room Temperature: **35 °F**    Ambient Temperature: **95 °F**    Design Run-time: **16 Hrs**    Required Capacity: **12,627 BTUH**

**Area Load**

Section	Material	Thickness	X - Factor	Surface Temp	Dim. 1	Dim. 2	Load
Wall 1	Polyurethane	4 in	0.1	95 °F	12 ft	8 ft	4,838.4 BTU
Wall 2	Polyurethane	4 in	0.1	95 °F	14 ft	8 ft	5,644.8 BTU
Wall 3	Polyurethane	4 in	0.1	95 °F	12 ft	8 ft	4,838.4 BTU
Wall 4	Polyurethane	4 in	0.1	95 °F	14 ft	8 ft	5,644.8 BTU
Ceiling	Polyurethane	4 in	0.1	110 °F	12 ft	14 ft	10,584 BTU
Floor	Concrete	6 in	1.3	65 °F	12 ft	14 ft	25,200 BTU
Total Area Load:							<b>56,750.4 BTU</b>

**Product Load - Auto Usage Selected**

Total Product Load: **25,804.8 BTU**

**Air Change Load**

Dry Bulb: <b>87.6 °F</b>	Wet Bulb: <b>71.7 °F</b>	
Door Type 1: <b>Man</b>	Number of Door Type 1: <b>1</b>	Door Usage: <b>Average</b>
Door Type 1: <b>Curtains: None</b>	Door Type 1 Curtain Efficiency: <b>0%</b>	Total Door Type 1 Load: <b>16,800 BTU</b>
		Total Air Change Load: <b>65,745.5 BTU</b>

**Miscellaneous Load**

People Load: <b>21,600 BTU</b>	Lighting Load: <b>13,769.3 BTU</b>	Motor Load: <b>0 BTU</b>
Other Load: <b>0 BTU</b>	Total Misc. Load: <b>35,369.3 BTU</b>	

**Load Calculation Summary**

Total Design Load: **183,670 BTU**    Safety Factor: **10%**    Total Required Load: **202,037 BTU**

## 12X14 COOLER - System Design Summary

---

### General Requirements

---

Room Temperature: <b>35 °F</b>	Ambient Temperature: <b>95 °F</b>	Design Run-time: <b>16 Hrs</b>	Required Capacity: <b>12627 BTUH</b>
Design TD: <b>10 °F</b>	Refrigerant: <b>R-448A</b>	Altitude: <b>0 FT</b>	

---

### Selected Equipment

---

Line Item	Quantity	Type	Tag	Description
1.0	1	System	12X14 COOLER	R-448A - Refrigeration Equipment Match 1
1.1	1	Condensing Unit	CDU-1	RFO150E4SDA
1.2	1	Unit Cooler	UC-1	RL6A094ADA

---

### System Balance

---

Balanced Capacity: <b>11,917.8 BTUH</b>	Evap. T.D.: <b>10.9 °F</b>	Line Loss: <b>2 °F</b>	Suction Temp: <b>22.1 °F</b>	Calc. Run-Time: <b>17 Hrs</b>
---	----------------------------	------------------------	------------------------------	-------------------------------

---

**12X14 COOLER - CDU-1 - Product Information****General Data**

Model Line: <b>NEXT-GEN MINI-CON</b>	Model Number: <b>RFO150E4SDA</b>	Flooded: <b>Yes</b>
Refrigerant: <b>R-448A</b>	Voltage: <b>208-230/1/60</b>	Compressor Type: <b>SCROLL</b>

**Performance Data**

Ambient Temp: <b>95 °F</b>	Suction Temp: <b>23 °F</b>	Capacity: <b>11,664 BTUH</b>
----------------------------	----------------------------	------------------------------

**Electrical Data**

Compressor RLA: <b>11.3</b>	Compressor LRA: <b>55</b>	Total Condenser Fan FLA: <b>1</b>
MCA: <b>16.1</b>	MOPD: <b>25</b>	

**Physical Data**

Number of Compressors: <b>1</b>	Compressor Model: <b>ZS11KAE</b>	Compressor HP: <b>1.5</b>
Number of Condenser Fans: <b>2</b>	Approx. Ship Weight: <b>205 lbs</b>	Sound Data: <b>71 dBA</b>
Liquid Line: <b>1/2 in.</b>	Suction Line: <b>7/8 in.</b>	
Pump Down Capacity (%): <b>90</b>	Pump Down Capacity: <b>11.6 lbs</b>	

**Option Data**

Mounted Option	NO STANDARD AIR DEFROST TIMER
Mounted Option	LIQUID LINE WITH COMPONENTS: SEALED FILTER & SIGHT GLASS
Mounted Option	STANDARD RECEIVER
Mounted Option	FIXED HIGH/ADJUSTABLE LOW PRESSURE CONTROL

**Compliance Data**

AWEF: **7.60**

**Notes**

## Dimensional Drawing

---

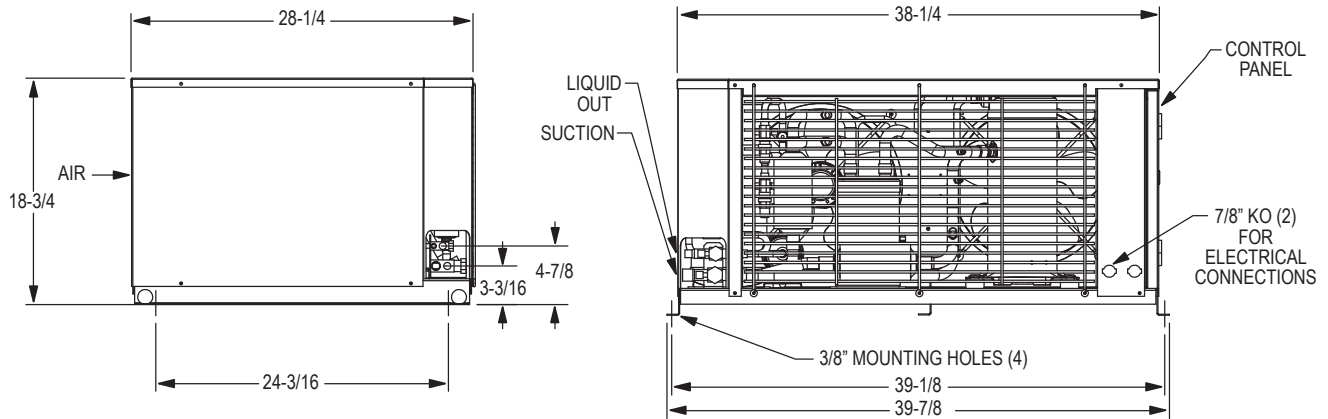

## Standard Features

---

- All-weather Galvanized steel painted housing
- Generously sized high efficiency condenser, enhanced copper tubes/aluminum fins
- Integral Liquid Subcooling Circuit provides subcooled liquid to the expansion device
- Crankcase heater
- Large electrical panel with hinged/removable door
- Color coded point-to-point wiring
- Quick access to shut off valves from exterior
- UL/cUL certified for use with multiple refrigerants
- UL/cUL listed for outdoor use
- Flooded models include flooded head pressure control
- Non flooded models include mild ambient fan cycle control

## Certifications

---



**12X14 COOLER - UC-1 - Product Information****General Data**

Model Line: <b>NEXT-GEN ALL-TEMP</b>	Model Number: <b>RL6A094ADA</b>	Motors: <b>DUAL SPEED EC MOTOR</b>
Unit Voltage: <b>115/1/60</b>	Defrost Type: <b>AIR DEFROST</b>	Refrigerant: <b>R-448A</b>
Fins Per Inch: <b>6</b>	Number of Fans: <b>2</b>	

**Performance Data**

Suction Temp: <b>25 °F</b>	T.D: <b>10.9 °F</b>	Capacity: <b>11,917.8 BTUH</b>	CFM: <b>1570</b>
----------------------------	---------------------	--------------------------------	------------------

**Electrical Data**

Motor Voltage: <b>115/1/60</b>	Total Unit Fan Motor Amps: <b>1.6</b>	
Heater Voltage: <b>115/1/60</b>	Heater Amps: <b>0</b>	Heater Watts: <b>0</b>
MCA: <b>15</b>	MOPD: <b>20</b>	

**Physical Data**

Liquid Line: <b>3/8 in.</b>	Suction Line: <b>5/8 in.</b>	Approx. Ship Weight: <b>55 lbs</b>
-----------------------------	------------------------------	------------------------------------

**Option Data**

Mounted Option	EcoNet Control Package
----------------	------------------------

**Compliance Data**

AWEF: **9.00**

**Notes**

## Dimensional Drawing

---

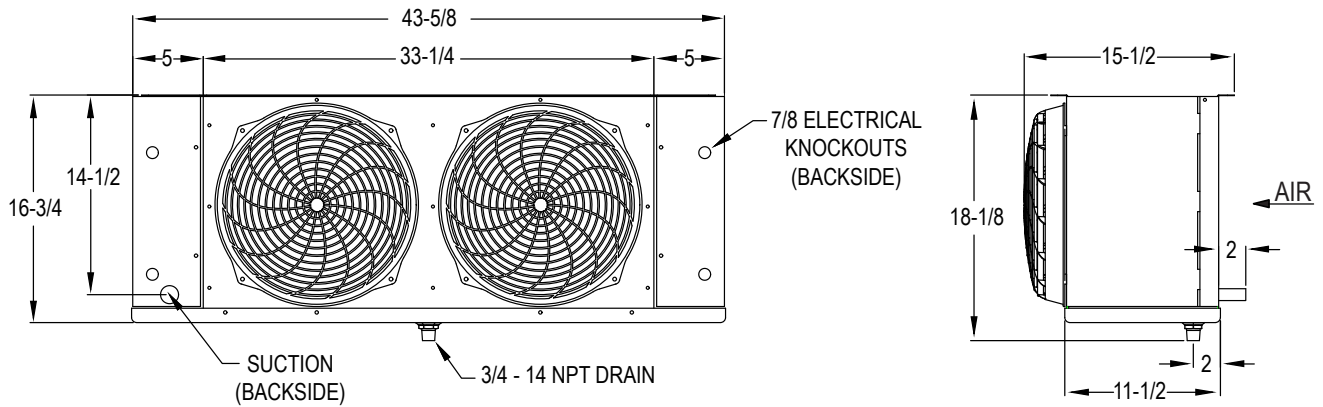

## Standard Features

---

- Embossed aluminum housing
- Enhanced copper tube and aluminum fin coil construction
- Sweat connections
- Thermal overload protection
- High efficiency fan guard design and deep draw venturi
- Heavy-duty fans are balanced for vibration-free operation
- Fan sections are baffled to prevent short cycling of air
- Slide out end panels
- Removable drain pan
- Mounts flush to the ceiling
- Top pan includes 1/2" wide slotted mounting points
- UL/cUL certified for use with multiple refrigerants
- NSF approved for use in food preparation areas

## Certifications

---

