



Date: Mar 10, 2024

Job: AWIC 8X9 FREEZER SINGLE PHASE

Customer: AWIC 8X9 FREEZER SINGLE PHASE

Customer Details: -

General Contractor: -

Submitted By: -



8X9 FREEZER - Box Load Calculation

General Requirements

Room Temperature: **-5 °F** Ambient Temperature: **95 °F** Design Run-time: **18 Hrs** Required Capacity: **8,853 BTUH**

Area Load

Section	Material	Thickness	X - Factor	Surface Temp	Dim. 1	Dim. 2	Load
Wall 1	Polyurethane	4 in	0.1	95 °F	8 ft	8 ft	5,376 BTU
Wall 2	Polyurethane	4 in	0.1	95 °F	9 ft	8 ft	6,048 BTU
Wall 3	Polyurethane	4 in	0.1	95 °F	8 ft	8 ft	5,376 BTU
Wall 4	Polyurethane	4 in	0.1	95 °F	9 ft	8 ft	6,048 BTU
Ceiling	Polyurethane	4 in	0.1	110 °F	8 ft	9 ft	6,955.2 BTU
Floor	Polyurethane	4 in	0.1	65 °F	8 ft	9 ft	4,233.6 BTU
Total Area Load:							34,036.8 BTU

Product Load - Auto Usage Selected

Total Product Load: **12,441.6 BTU**

Air Change Load

Dry Bulb: 87.6 °F	Wet Bulb: 71.7 °F	
Door Type 1: Man	Number of Door Type 1: 1	Door Usage: Average
Door Type 1: Curtains: None	Door Type 1 Curtain Efficiency: 0%	Total Door Type 1 Load: 16,800 BTU
		Total Air Change Load: 58,889.3 BTU

Miscellaneous Load

People Load: 33,600 BTU	Lighting Load: 5,901.1 BTU	Motor Load: 0 BTU
Other Load: 0 BTU	Total Misc. Load: 39,501.1 BTU	

Load Calculation Summary

Total Design Load: **144,868.8 BTU** Safety Factor: **10%** Total Required Load: **159,355.7 BTU**

8X9 FREEZER - System Design Summary

General Requirements

Room Temperature: -5 °F	Ambient Temperature: 95 °F	Design Run-time: 18 Hrs	Required Capacity: 8853 BTUH
Design TD: 10 °F	Refrigerant: R-448A	Altitude: 0 FT	

Selected Equipment

Line Item	Quantity	Type	Tag	Description
1.0	1	System	8X9 FREEZER	R-448A - Refrigeration Equipment Match 1
1.1	1	Condensing Unit	CDU-1	RFO250L4SDA
1.2	1	Unit Cooler	UC-1	RL6E077DDA

System Balance

Balanced Capacity: 9,046.6 BTUH	Evap. T.D.: 10.1 °F	Line Loss: 2 °F	Suction Temp: -17.1 °F	Calc. Run-Time: 17.6 Hrs
--	----------------------------	------------------------	-------------------------------	---------------------------------

8X9 FREEZER - CDU-1 - Product Information**General Data**

Model Line: NEXT-GEN MINI-CON	Model Number: RFO250L4SDA	Flooded: Yes
Refrigerant: R-448A	Voltage: 208-230/1/60	Compressor Type: SCROLL

Performance Data

Ambient Temp: 95 °F	Suction Temp: -17 °F	Capacity: 8,688 BTUH
----------------------------	-----------------------------	-----------------------------

Electrical Data

Compressor RLA: 14.7	Compressor LRA: 73	Total Condenser Fan FLA: 1
MCA: 30.4	MOPD: 45	

Physical Data

Number of Compressors: 1	Compressor Model: ZF08K4E	Compressor HP: 2.5
Number of Condenser Fans: 2	Approx. Ship Weight: 240 lbs	Sound Data: 73 dBA
Liquid Line: 3/8 in.	Suction Line: 7/8 in.	
Pump Down Capacity (%): 90	Pump Down Capacity: 14.3 lbs	

Option Data

Mounted Option	ADD/MODIFY DEFROST KIT: ED5
Mounted Option	LIQUID LINE WITH COMPONENTS: SEALED FILTER & SIGHT GLASS
Mounted Option	STANDARD RECEIVER
Mounted Option	FIXED HIGH/ADJUSTABLE LOW PRESSURE CONTROL

Compliance Data

AWEF: **3.15**

Notes

Dimensional Drawing

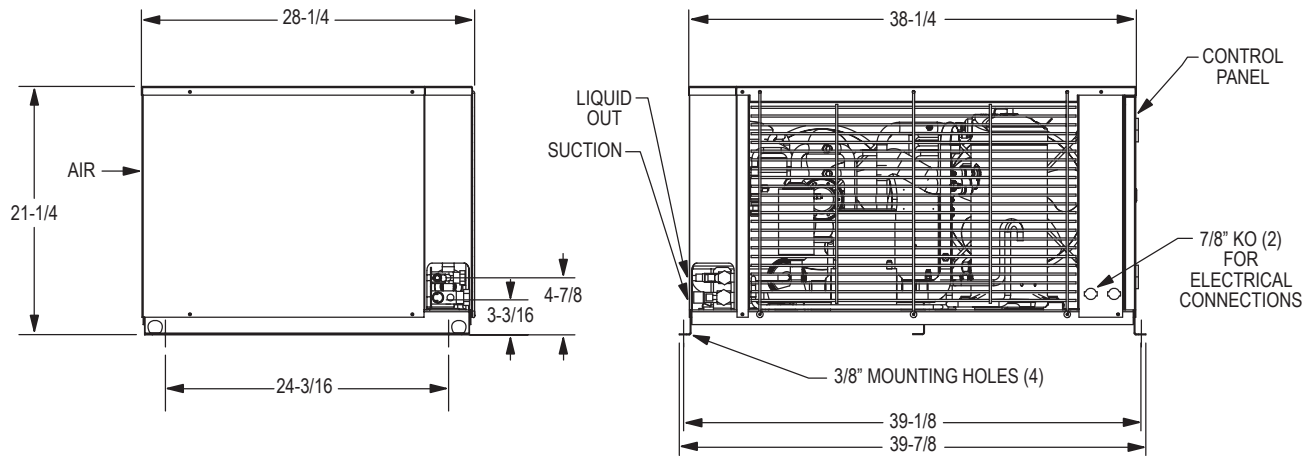

Standard Features

- All-weather Galvanized steel painted housing
- Generously sized high efficiency condenser, enhanced copper tubes/aluminum fins
- Integral Liquid Subcooling Circuit provides subcooled liquid to the expansion device
- Crankcase heater
- Large electrical panel with hinged/removable door
- Color coded point-to-point wiring
- Quick access to shut off valves from exterior
- UL/cUL certified for use with multiple refrigerants
- UL/cUL listed for outdoor use
- Flooded models include flooded head pressure control
- Non flooded models include mild ambient fan cycle control

Certifications



8X9 FREEZER - UC-1 - Product Information**General Data**

Model Line: NEXT-GEN ALL-TEMP	Model Number: RL6E077DDA	Motors: DUAL SPEED EC MOTOR
Unit Voltage: 208-230/1/60	Defrost Type: ELECTRIC DEFROST	Refrigerant: R-448A
Fins Per Inch: 6	Number of Fans: 2	

Performance Data

Suction Temp: -15 °F	T.D: 10.1 °F	Capacity: 9,046.6 BTUH	CFM: 1570
-----------------------------	---------------------	-------------------------------	------------------

Electrical Data

Motor Voltage: 208-230/1/60	Total Unit Fan Motor Amps: 1	
Heater Voltage: 208-230/1/60	Heater Amps: 9.8	Heater Watts: 2250
MCA: 15	MOPD: 20	

Physical Data

Liquid Line: 3/8 in.	Suction Line: 7/8 in.	Approx. Ship Weight: 55 lbs
-----------------------------	------------------------------	------------------------------------

Option Data

Mounted Option	EcoNet Control Package
Mounted Option	Fixed Defrost Control / Fan Delay Switch

Compliance Data

AWEF: 4.15

Notes

Dimensional Drawing

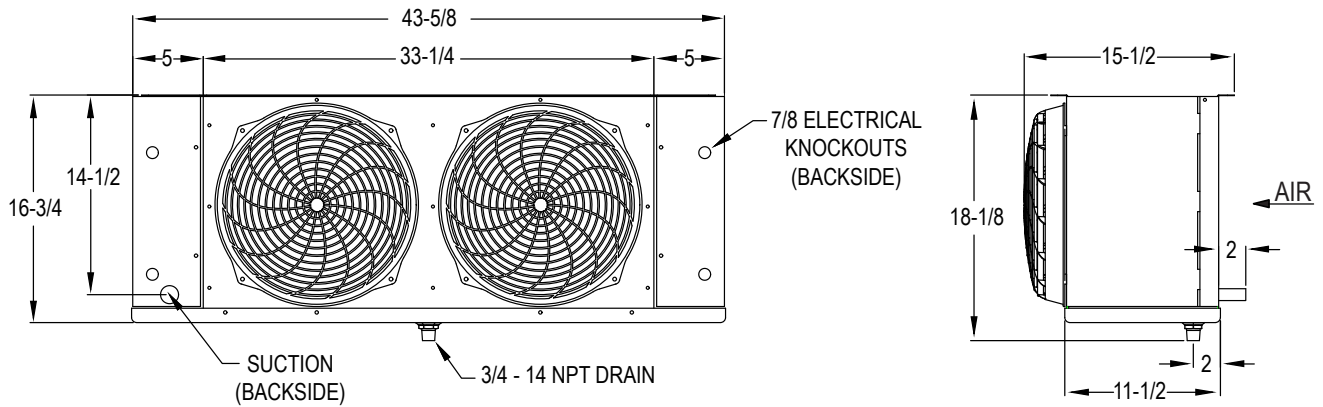

Standard Features

- Embossed aluminum housing
- Enhanced copper tube and aluminum fin coil construction
- Sweat connections
- Thermal overload protection
- High efficiency fan guard design and deep draw venturi
- Heavy-duty fans are balanced for vibration-free operation
- Fan sections are baffled to prevent short cycling of air
- Slide out end panels
- Removable drain pan
- Mounts flush to the ceiling
- Top pan includes $1/2$ " wide slotted mounting points
- UL/cUL certified for use with multiple refrigerants
- NSF approved for use in food preparation areas

Certifications

