



Date: Mar 10, 2024

Job: AWIC 7X9 FREEZER SINGLE PHASE

Customer: AWIC 7X9 FREEZER SINGLE PHASE

Customer Details: -

General Contractor: -

Submitted By: -



7X9 FREEZER - Box Load Calculation**General Requirements**

Room Temperature: **-5 °F** Ambient Temperature: **95 °F** Design Run-time: **18 Hrs** Required Capacity: **8,771 BTUH**

Area Load

Section	Material	Thickness	X - Factor	Surface Temp	Dim. 1	Dim. 2	Load
Wall 1	Polyurethane	4 in	0.1	95 °F	7 ft	8 ft	4,704 BTU
Wall 2	Polyurethane	4 in	0.1	95 °F	10 ft	8 ft	6,720 BTU
Wall 3	Polyurethane	4 in	0.1	95 °F	7 ft	8 ft	4,704 BTU
Wall 4	Polyurethane	4 in	0.1	95 °F	10 ft	8 ft	6,720 BTU
Ceiling	Polyurethane	4 in	0.1	110 °F	7 ft	10 ft	6,762 BTU
Floor	Polyurethane	4 in	0.1	65 °F	7 ft	10 ft	4,116 BTU
Total Area Load:							33,726 BTU

Product Load - Auto Usage Selected

Total Product Load: **12,096 BTU**

Air Change Load

Dry Bulb: 87.6 °F	Wet Bulb: 71.7 °F	
Door Type 1: Man	Number of Door Type 1: 1	Door Usage: Average
Door Type 1: Curtains: None	Door Type 1 Curtain Efficiency: 0%	Total Door Type 1 Load: 16,800 BTU
		Total Air Change Load: 58,361.4 BTU

Miscellaneous Load

People Load: 33,600 BTU	Lighting Load: 5,737.2 BTU	Motor Load: 0 BTU
Other Load: 0 BTU	Total Misc. Load: 39,337.2 BTU	

Load Calculation Summary

Total Design Load: **143,520.6 BTU** Safety Factor: **10%** Total Required Load: **157,872.7 BTU**

7X9 FREEZER - System Design Summary

General Requirements

Room Temperature: -5 °F	Ambient Temperature: 95 °F	Design Run-time: 18 Hrs	Required Capacity: 8771 BTUH
Design TD: 10 °F	Refrigerant: R-448A	Altitude: 0 FT	

Selected Equipment

Line Item	Quantity	Type	Tag	Description
1.0	1	System	7X10 FREEZER	R-448A - Refrigeration Equipment Match 1
1.1	1	Condensing Unit	CDU-1	RFO250L4SDA
1.2	1	Unit Cooler	UC-1	RL6E077DDA

System Balance

Balanced Capacity: 9,046.6 BTUH	Evap. T.D.: 10.1 °F	Line Loss: 2 °F	Suction Temp: -17.1 °F	Calc. Run-Time: 17.5 Hrs
--	----------------------------	------------------------	-------------------------------	---------------------------------

Quotes are valid for 30 Days. Due to ongoing product development, RapidSpec and its export documentation is subject to change without notice. In no event shall HTPG be liable for special or consequential damages in connection with the use or output of RapidSpec.

7X10 FREEZER - CDU-1 - Product Information**General Data**

Model Line: NEXT-GEN MINI-CON	Model Number: RFO250L4SDA	Flooded: Yes
Refrigerant: R-448A	Voltage: 208-230/1/60	Compressor Type: SCROLL

Performance Data

Ambient Temp: 95 °F	Suction Temp: -17 °F	Capacity: 8,688 BTUH
----------------------------	-----------------------------	-----------------------------

Electrical Data

Compressor RLA: 14.7	Compressor LRA: 73	Total Condenser Fan FLA: 1
MCA: 30.4	MOPD: 45	

Physical Data

Number of Compressors: 1	Compressor Model: ZF08K4E	Compressor HP: 2.5
Number of Condenser Fans: 2	Approx. Ship Weight: 240 lbs	Sound Data: 73 dBA
Liquid Line: 3/8 in.	Suction Line: 7/8 in.	
Pump Down Capacity (%): 90	Pump Down Capacity: 14.3 lbs	

Option Data

Mounted Option	ADD/MODIFY DEFROST KIT: ED5
Mounted Option	LIQUID LINE WITH COMPONENTS: SEALED FILTER & SIGHT GLASS
Mounted Option	STANDARD RECEIVER
Mounted Option	FIXED HIGH/ADJUSTABLE LOW PRESSURE CONTROL

Compliance Data

AWEF: **3.15**

Notes

Dimensional Drawing

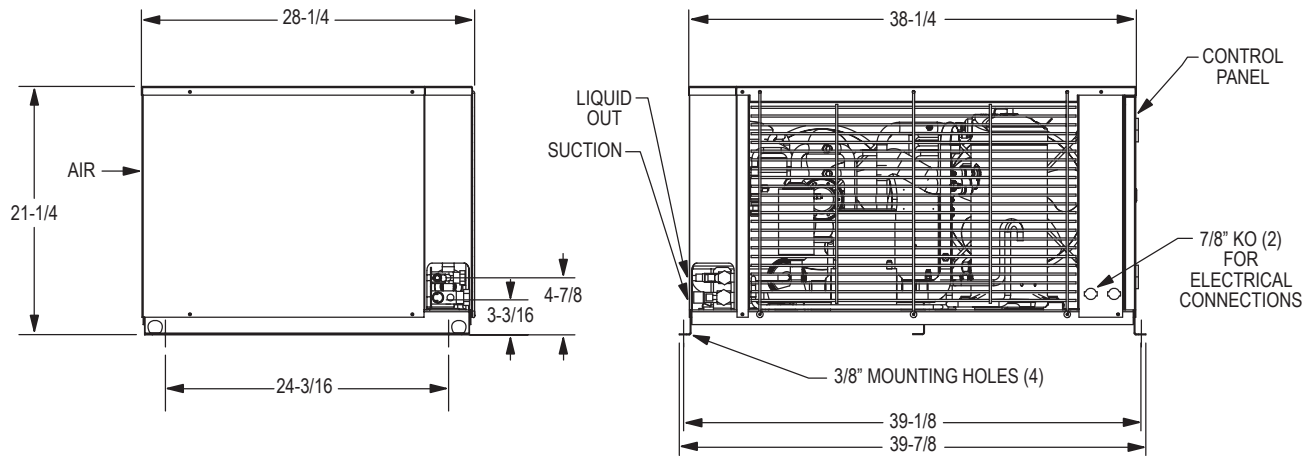

Standard Features

- All-weather Galvanized steel painted housing
- Generously sized high efficiency condenser, enhanced copper tubes/aluminum fins
- Integral Liquid Subcooling Circuit provides subcooled liquid to the expansion device
- Crankcase heater
- Large electrical panel with hinged/removable door
- Color coded point-to-point wiring
- Quick access to shut off valves from exterior
- UL/cUL certified for use with multiple refrigerants
- UL/cUL listed for outdoor use
- Flooded models include flooded head pressure control
- Non flooded models include mild ambient fan cycle control

Certifications



7X9 FREEZER - UC-1 - Product Information**General Data**

Model Line: NEXT-GEN ALL-TEMP	Model Number: RL6E077DDA	Motors: DUAL SPEED EC MOTOR
Unit Voltage: 208-230/1/60	Defrost Type: ELECTRIC DEFROST	Refrigerant: R-448A
Fins Per Inch: 6	Number of Fans: 2	

Performance Data

Suction Temp: -15 °F	T.D: 10.1 °F	Capacity: 9,046.6 BTUH	CFM: 1570
-----------------------------	---------------------	-------------------------------	------------------

Electrical Data

Motor Voltage: 208-230/1/60	Total Unit Fan Motor Amps: 1	
Heater Voltage: 208-230/1/60	Heater Amps: 9.8	Heater Watts: 2250
MCA: 15	MOPD: 20	

Physical Data

Liquid Line: 3/8 in.	Suction Line: 7/8 in.	Approx. Ship Weight: 55 lbs
-----------------------------	------------------------------	------------------------------------

Option Data

Mounted Option	EcoNet Control Package
Mounted Option	Fixed Defrost Control / Fan Delay Switch

Compliance Data

AWEF: 4.15

Notes

Dimensional Drawing

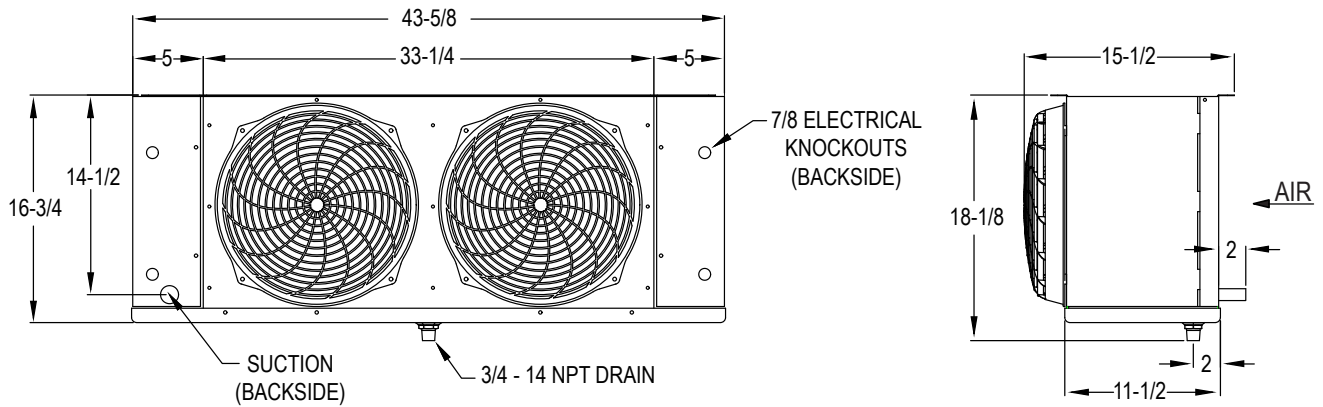

Standard Features

- Embossed aluminum housing
- Enhanced copper tube and aluminum fin coil construction
- Sweat connections
- Thermal overload protection
- High efficiency fan guard design and deep draw venturi
- Heavy-duty fans are balanced for vibration-free operation
- Fan sections are baffled to prevent short cycling of air
- Slide out end panels
- Removable drain pan
- Mounts flush to the ceiling
- Top pan includes $\frac{1}{2}$ " wide slotted mounting points
- UL/cUL certified for use with multiple refrigerants
- NSF approved for use in food preparation areas

Certifications

